



This product, formerly sold by ams AG, and before that optionally by either Applied Sensors GmbH, acam-messelectronic GmbH or Cambridge CMOS Sensors, is now owned and sold by

# SciSense

The technical content of this document under ams / Applied Sensors / acam-messelectronic / Cambridge CMOS Sensors is still valid.

## Contact information

### Headquarters:

**Sciosense B.V.**

High Tech Campus 10

5656 AE Eindhoven

The Netherlands

[info@sciosense.com](mailto:info@sciosense.com)

[www.sciosense.com](http://www.sciosense.com)

# Knowing precisely where to go

[www.ams.com/AS6501](http://www.ams.com/AS6501)



## AS6501 – 2-Channel TDC for Laser Scanners

- Industry's best combination of speed, precision and power
- Resolution on each channel down to 10ps rms
- High measurement rate up to 70 MSamples/s
- Only 260 mW at maximum sample rate with LVDS readout

**Sensing  
is life.**

## General Description

The AS6501 features high-speed LVDS interfaces for the Start and Stop signals in optical ranging equipment and scanners, as well as LVDS measurement outputs. It can be used to measure the time-of-flight of optical signals to a precision of 20ps per channel, or 10ps in dual-channel high-resolution mode, and captures measurements at very high speeds of up to 70Msamples/s.

Single-beam laser ranging systems based on the precise, high-speed AS6501 can render extremely accurate and detailed outlines of objects in the field of view – an essential requirement for vehicles' new assisted and autonomous driving systems. Positron emission tomography (PET) medical imaging systems can also use the AS6501 to produce highly detailed images of a patient's body.

By optimizing the AS6501 for single-beam applications, ams has been able to combine high performance with compact dimensions. The two-channel AS6501 is housed in a QFP48 package measuring just 7mm x 7mm, a 40 percent reduction in board footprint compared to its four-channel counterpart, the TDC-GPX2. The AS6501, which includes on-board logic for measuring the time interval between the Start and Stop signals, requires few external components.

Power consumption is up to 10 times lower than competing TDCs that offer a similar level of precision. For example, the typical power consumption in normal operation is just 260mW at a supply voltage of 3.3V. Stand-by current is 60µA.

## Applications

- Laser range finders
- Laser scanners in robots
- ADAS
- PET imaging
- ToF spectroscopy
- Particle detection
- ATE

## Features

- Two stop channels with serial 20ns pulse-to-pulse spacing at maximum 35 MSPS
- One combined channel with 5ns pulse-to-pulse spacing at maximum 70 MSPS
- Single shot accuracy 20ps rms per channel, 10ps rms with high resolution option
- Unlimited measuring range 0s to 16s
- Inputs optional with LVDS or CMOS level
- Readout with LVDS or SPI
- Automatic calibration to reference clock
- Power dissipation 60 to 260mW
- QFP48 package (7x7 mm<sup>2</sup>)

## AS6501 Block Diagram

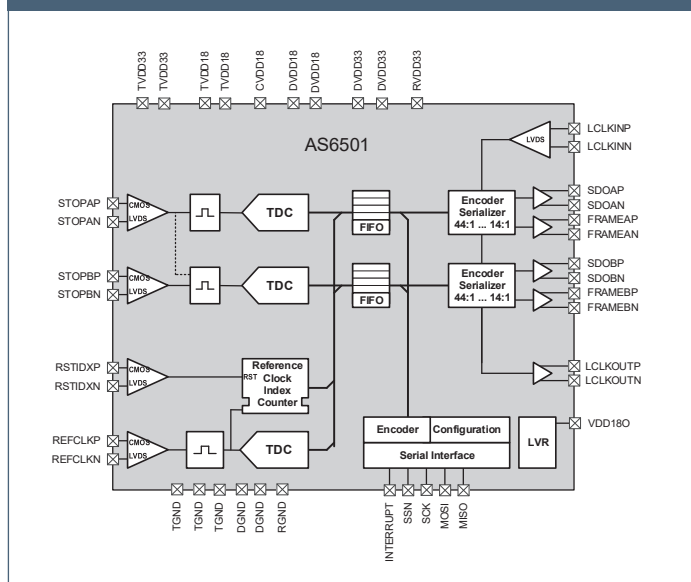

## Benefits

- Simple data post-processing thanks to calibrated results
- Event assignment thanks to reference clock index simplifies coincidence measurements
- High efficiency thanks to high sample rate
- High contrast thanks to high resolution

www.ams.com  
 sensors@ams.com  
 © 08/2018 by ams  
 Subject to change without notice

**Headquarters**  
**ams AG**  
 Tobelbader Strasse 30, 8141 Premstaetten, Austria  
 Phone +43 3136 500-0

**Sales Offices Worldwide**  
 sales-europe@ams.com  
 sales-asia@ams.com  
 sales-americas@ams.com