



This product, formerly sold by ams AG, and before that optionally by either Applied Sensors GmbH, acam-messelectronic GmbH or Cambridge CMOS Sensors, is now owned and sold by

SciSense

The technical content of this document under ams / Applied Sensors / acam-messelectronic / Cambridge CMOS Sensors is still valid.

Contact information

Headquarters:

Sciosense B.V.

High Tech Campus 10

5656 AE Eindhoven

The Netherlands

info@sciosense.com

www.sciosense.com



austriamicrosystems AG

is now

ams AG

The technical content of this austriamicrosystems application note is still valid.

Contact information:

Headquarters:

ams AG

Tobelbaderstrasse 30

8141 Unterpremstaetten, Austria

Tel: +43 (0) 3136 500 0

e-Mail: ams_sales@ams.com

Please visit our website at www.ams.com

AS3932

Application Note AS3932

Migration from ATA5283 (1-channel) to AS3932

Date: 09/02/2009

Revision: 1.0

ams AG
Technical content still valid

Contents

1	INTRODUCTION	3
2	COMPARISON OF THE HARDWARE	3
2.1	APPLICATION DIAGRAMS	3
2.2	OSCILLATOR FREQUENCY	4
2.3	SERIAL DIGITAL INTERFACE.....	5
2.4	WAKEUP AND DATA PIN	5
2.5	MANCHESTER CLOCK RECOVERY	5
3	PROTOCOL COMPATIBILITY	5

1 Introduction

This document shows how to easily migrate from ATA5283 to AS3932.

2 Comparison of the Hardware

2.1 Application diagrams

The figures 2-1 and 2-2 show the application diagram of ATA5283 and AS3932, respectively.

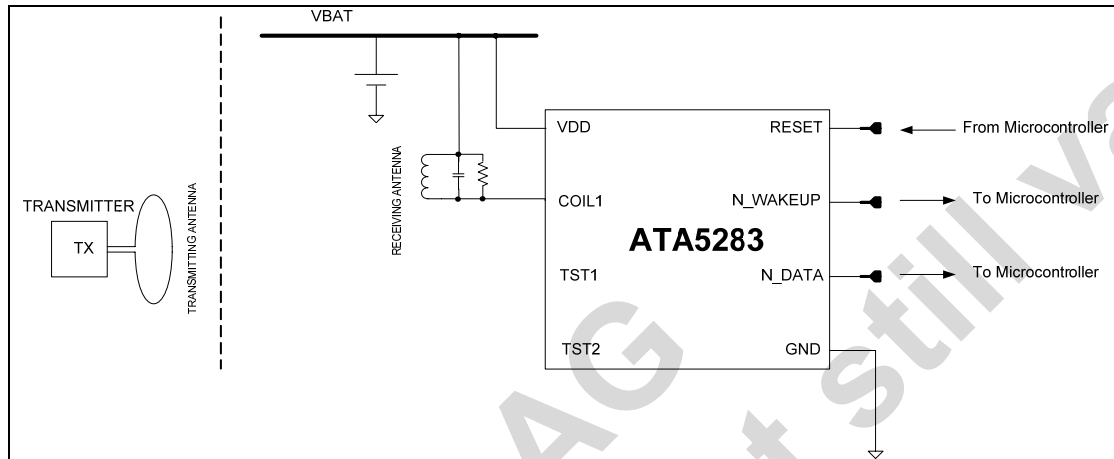

Figure 2-1: Application diagram of ATA5283

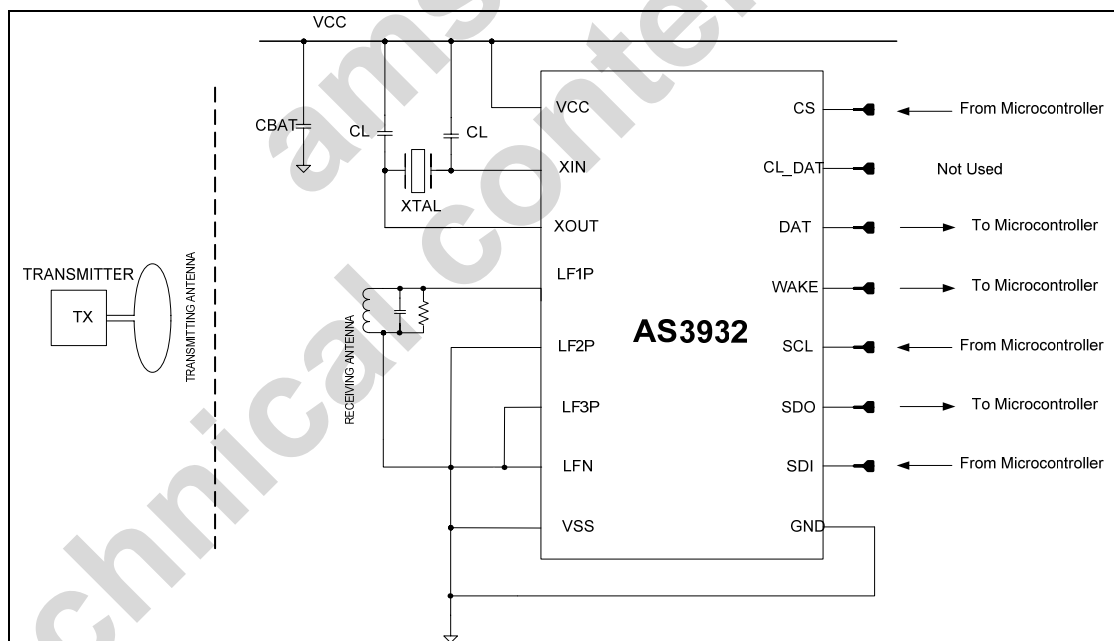

Figure 2-2: Application diagram of AS3932

ATA5283 is a single channel wakeup receiver, while AS3932 has three channels available. Therefore it is mandatory to connect the channels 2 and 3 (LF2P and LF3P) of AS3932 to a fixed DC potential (either GND or VCC) and to disable them in the register map via SDI (see chapter 3). The ATA5283 application block diagram shows that the input antenna has to be referenced to the positive supply, while the AS3932 block diagram shows that the inputs are referenced to ground. In addition AS3932 offers the possibility to reference the input to the positive potential, as shown in the next figure 2-3. This modification will not influence the performance of AS3932.

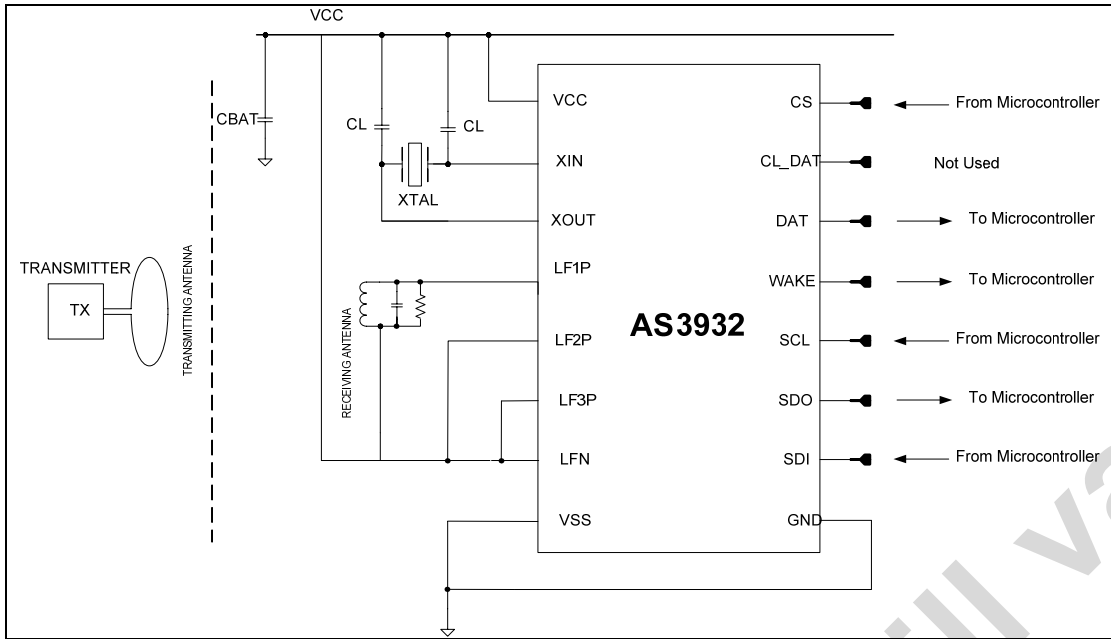

Figure 2-3: Alternative application diagram of AS3932.

2.2 Oscillator frequency

The ATA5283 has no Real Time Clock (RTC), while the AS3932 has a RTC that either uses a crystal oscillator or the fully integrated RC oscillator. In case a crystal oscillator is used, a 32768 Hz quartz and two capacitors (specified by the crystal manufacturer) are needed for AS3932.

AS3932 also offers the possibility to define the oscillator frequency using the internal RC-oscillator. This oscillator can be calibrated with the microcontroller (see p. 27 of AS3932 data sheet) in order to increase its precision. In this case the XIN and XOUT have to be connected to the positive supply voltage, as shown in figure 2-4.

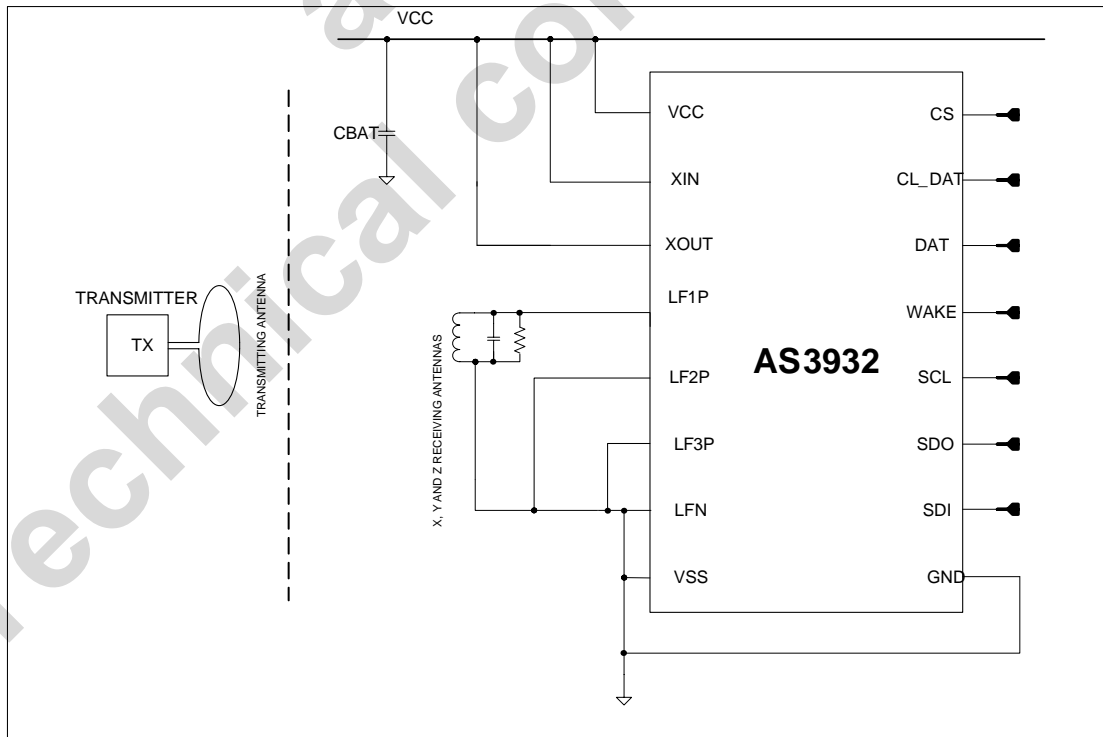

Figure 2-4: Application diagram of AS3932 in case the RC-oscillator is used.

2.3 Serial Digital Interface

The AS3932 has a 4-wire serial data interface (CS, SDI, SDO, SCL) while the ATA5283 has no interface, since no programmability is allowed. The Serial Digital Interface of AS3932 needs to be programmed accordingly (see p. 16 to p. 18 of AS3932 data sheet).

2.4 Wakeup and data pin

Both AS3932 and ATA5283 have two dedicated pins for the wakeup and data; the only difference is that the wakeup pin of ATA5283 (WAKEUP) has an inverted meaning compared to AS3932 (WAKEUP=high=no wakeup, WAKEUP=low=wakeup)

2.5 Manchester clock recovery

Furthermore the AS3932 has a fully integrated Manchester clock recovery, which provides the recovered clock on the pin CL_DAT. This pin is missing in the ATA5283, thus no clock recovery is possible. In case clock recovery is not required, the pin CL_DAT of AS3932 can remain floating.

3 Protocol compatibility

The ATA5283 wakes up if a carrier burst of at least 704 periods is followed by a "start gap" (no Signal); an example is given in the figure 3-1.

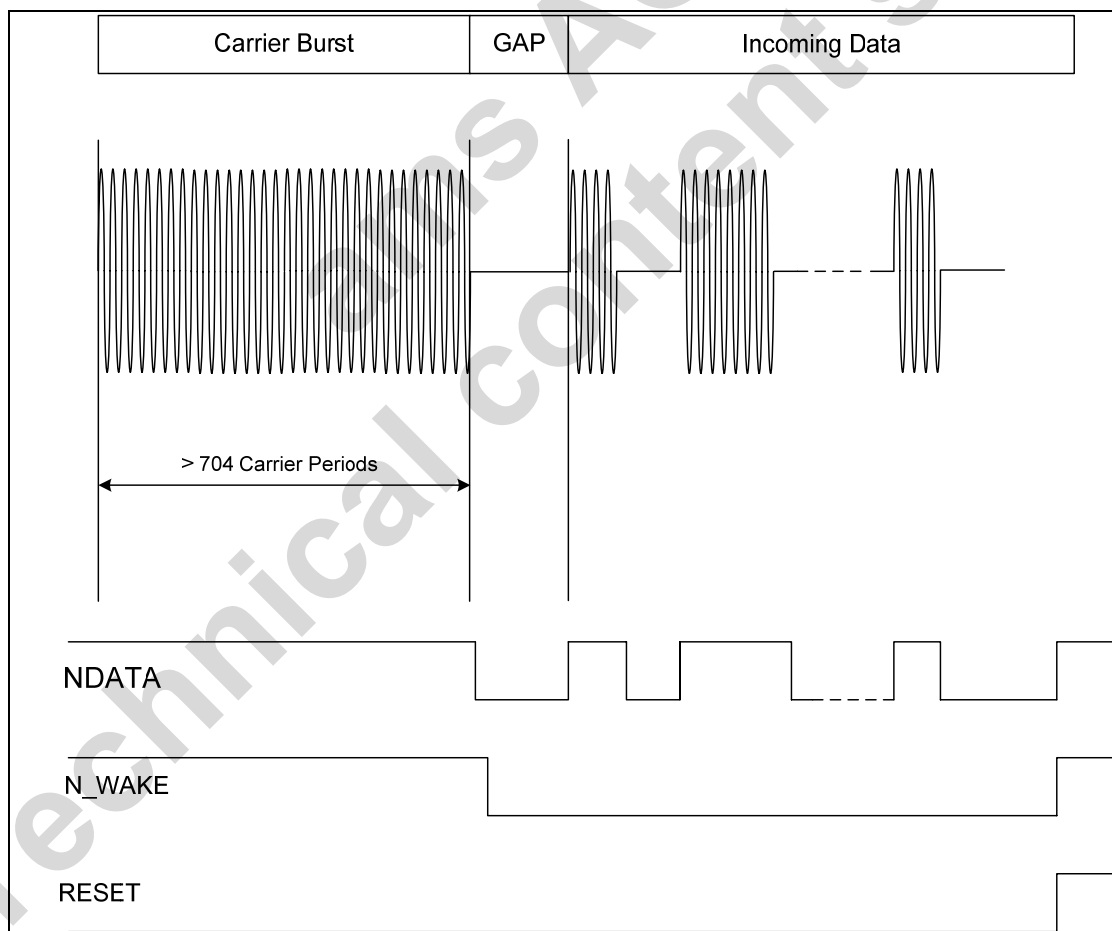

Figure 3-1: ATA5283 wakeup protocol description

In order to have full compatibility to ATA5283, AS3932 should be set to frequency detection only (R1<1>=0). In this way the AS3932 will react to the presence of the carrier signal (WAKE signal goes high as soon as the carrier

signal is detected). The minimum duration of the carrier burst is 360us for AS3932. To wake the AS3932 up, no "start gap" is needed, as shown in the figure 3-2.

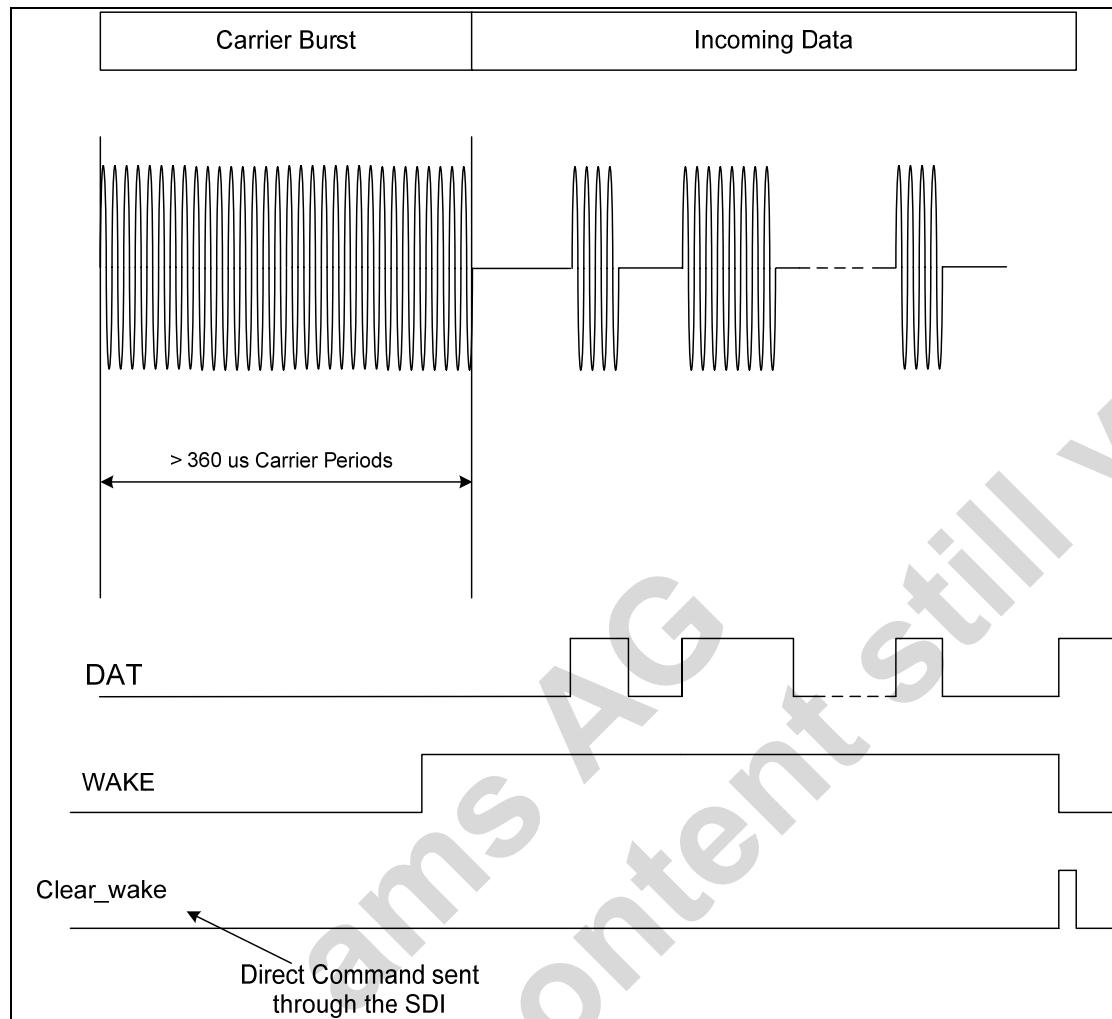

Figure 3-2: AS3932 wakeup protocol description

The procedure to set up the AS3932 working in this way is described below.

- Send the preset_default direct command
- Write in the register R0<7:0> 02 (HEX) This ensures that Channel 2 and Channel 3 are disabled in order to reduce the current consumption.
- Write R1<7:0> 21 (HEX) in case the crystal oscillator is used or write R1<7:0> 20 (HEX) if the RC oscillator is used. In this way the wakeup will occur only based on frequency detection.
- Set the envelop detector time constant (R3<2:0>) according to the used bit rate (see p. 20 of AS3932 data sheet).

Contact

austriamicrosystems AG
A 8141 Schloss Premstaetten, Austria
T. +43 (0) 3136 500 0
F. +43 (0) 3136 525 01
wireless@austriamicrosystems.com

Copyright

Copyright © 2009 austriamicrosystems. Trademarks registered ®. All rights reserved. The material herein may not be reproduced, adapted, merged, translated, stored, or used without the prior written consent of the copyright owner.

To the best of its knowledge, austriamicrosystems asserts that the information contained in this publication is accurate and correct. austriamicrosystems reserves the right to discontinue production and change specifications and prices, make corrections, modifications, enhancements, improvements and other changes of its products and services at any time without notice.

Technical content still valid
ams AG